

4. STENDER & GONDOLA



4.1 round tube clothes-stand p. 412



4.2 square tube clothes-stand p. 442



4.3 folding clothes-stand p. 452



4.4 gondole p. 460



4.5 special for representatives p. 466



4.6 accessories p. 468







Stender
in tubo tondo

STG001

Round garment rails of essential geometry, in tube Ø 30 mm





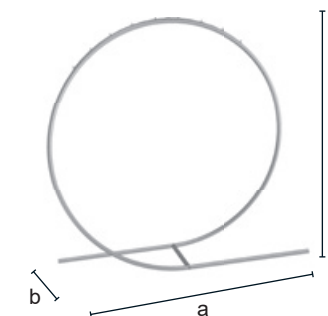

STG001	
 mm	h = 1600 a = 1600 b = 550
 Kg	11,00
 Pcs	40/pallet
	VS V
€	160,00 126,00



STG002

Big-size rectangular garment rails of essential geometry, in tube Ø 30 mm.



STG002	
 mm	h = 1600 a = 1500 b = 550
 Kg	12,50
 Pcs	40/pallet
	VS V
€	140,00 95,00

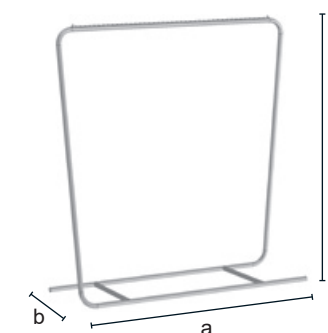



4.1 stender TT

4.1 stender TT



STG003

Small-size rectangular garment rails of essential geometry, in tube Ø 30 mm.



	STG003	
	h = 1600	
	a = 900	
	b = 550	
	Kg 9,00	
	Pcs 40/pallet	
	VS	V
	€ 130,00	91,00

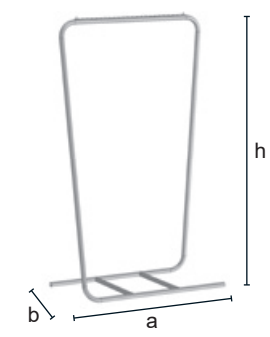

4.1 stender TT

4.1 stender TT



ST010R50F

Wheels Ø 50 mm

ST010R80F

Wheels Ø 80 mm

Fixed single clothes stand, width cm 150. Tube Ø 30 mm.



	ST010R50F	ST010R80F
	h = 1490 a = min 1500 max 2200 b = 570	h = 1540 a = min 1500 max 2200 b = 570
	6,80	7,60
	50/pallet	50/pallet
	CR	CR
€	51,00	54,00

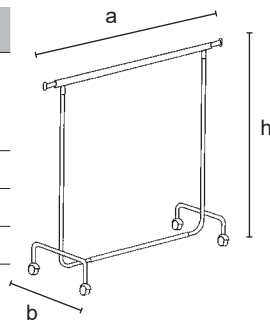

ST012R50F

Wheels Ø 50 mm

ST012R80F

Wheels Ø 80 mm

Fixed single clothes stand, width cm 100. Tube Ø 30 mm.



	ST012R50F	ST012R80F
	h = 1495 a = min 1000 max 1700 b = 570	h = 1540 a = min 1000 max 1700 b = 570
	6,00	6,80
	50/pallet	50/pallet
	CR	CR
€	45,00	49,00

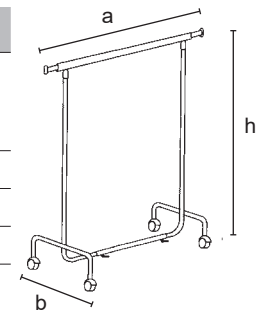

ST010R50R

Wheels Ø 50 mm

ST010R80R

Wheels Ø 80 mm

Adjustable single clothes stand, width cm 150. Tube Ø 30 mm. Clamping with system "A" or "B".



Sistema "A" Sistema "B"

	ST010R50R	ST010R80R
	h = min 1300 max 2030 a = min 1500 max 2200 b = 570	h = min 1350 max 2000 a = min 1500 max 2200 b = 570
	7,70	8,50
	50/pallet	50/pallet
	CR	CR
"A" €	56,00	59,00
"B" €	60,00	63,00

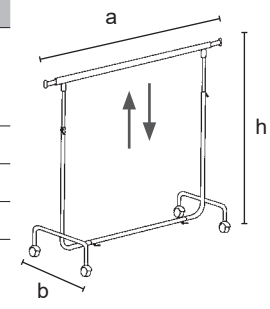

ST012R50R

Wheels Ø 50 mm

ST012R80R

Wheels Ø 80 mm

Adjustable single clothes stand, width cm 100. Tube Ø 30 mm. Clamping with system "A" or "B".

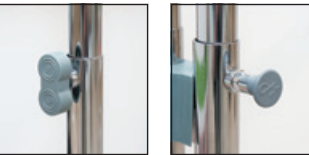

Sistema "A" Sistema "B"

	ST012R50R	ST012R80R
	h = min 1300 max 2030 a = min 1000 max 1700 b = 570	h = min 1350 max 2000 a = min 1000 max 1700 b = 570
	6,90	7,70
	100/pallet	100/pallet
	CR	CR
"A" €	51,00	54,00
"B" €	55,00	58,00

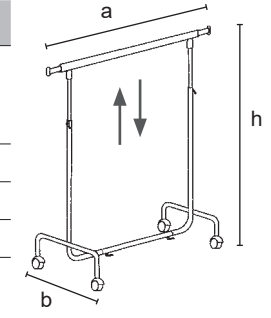

4.1 stender TT

4.1 stender TT

ST150 - (ST010R50-80F) ST100 - (ST012R50-80F)

Height-adjustable middle bar for stender tube Ø 30 mm.



	ST150	ST100
	a = 1360 b = 50 c = 30	a = 860 b = 50 c = 30
mm		
	2,00	0,85
	300/pallet	300/pallet
	CR	CR
€	19,00	18,00

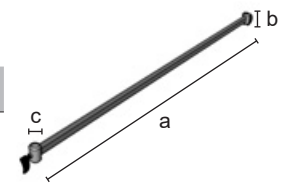

ST150R - (ST010R50R) ST100R - (ST012R50R)

Height-adjustable middle bar for stender. Clamping with system "A" or "B".



	ST150R	ST100R
	a = 1360 b = 50 c = 26	a = 860 b = 50 c = 26
mm		
	2,00	0,85
	300/pallet	300/pallet
	CR	CR
"A" €	20,00	18,00
"B" €	24,00	22,00

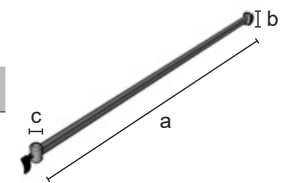
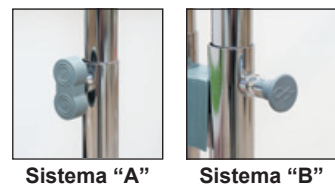

ST11PRO

Legs extensions for coat-rack ST010R50-80F / ST012R50-80F, necessary to increase the height of the coat-rack facilitating the use of the middle bar.



	ST11PRO
	h = 500 a = 28
mm	
	1,20
	50/box
	CR
€	7,50 (2 pcs)

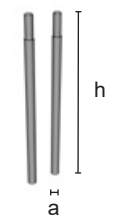

4.1 stender TT

4.1 stender TT



ST011R50F (ST010R50F + ST11PRO + ST150)
Wheels Ø 50 mm

ST011R80F (ST010R80F + ST11PRO + ST150)
Wheels Ø 80 mm

Fixed double clothes stand, width cm 150. Tube Ø 30 mm. Central rail which can be fixed along all height for clamping. Clamping by means of levers.

	ST011R50F	ST011R80F
mm	h = 1940	h = 1990
mm	a = min 1500 max 2200	a = min 1500 max 2200
Kg	8,80	9,60
Pcs	50/pallet	50/pallet
CR	CR	CR
€	76,00	80,00

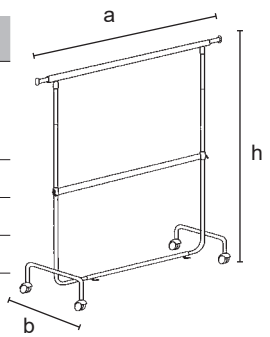

ST013R50F (ST012R50F + ST11PRO + ST100)
Wheels Ø 50 mm

ST013R80F (ST012R80F + ST11PRO + ST100)
Wheels Ø 80 mm

Fixed double clothes stand, width cm 100. Tube Ø 30 mm. Central rail which can be fixed along all height for clamping. Clamping by means of levers.

	ST013R50F	ST013R80F
mm	h = 1940	h = 1990
mm	a = min 1000 max 1700	a = min 1000 max 1700
Kg	7,60	8,50
Pcs	50/pallet	50/pallet
CR	CR	CR
€	70,00	73,00

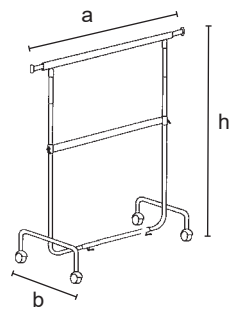

ST011R50R (ST010R50R + ST150R)
Wheels Ø 50 mm

ST011R80R (ST010R80R + ST150R)
Wheels Ø 80 mm

Double clothes stand, width cm 150. Tube Ø 30 mm. Central and upper adjustable rail. Clamping with system "A" or "B".

	ST011R50R	ST011R80R
mm	h = min 1300 max 2030	h = min 1350 max 2000
mm	a = min 1500 max 2200	a = min 1500 max 2200
Kg	9,70	10,50
Pcs	50/pallet	50/pallet
CR	CR	CR
€	75,00	79,00
€	84,00	87,00

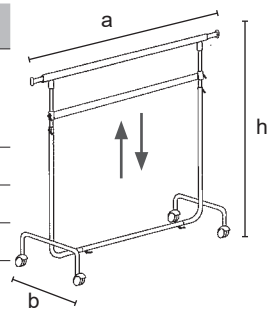

ST013R50R (ST012R50R + ST100R)
Wheels Ø 50 mm

ST013R80R (ST012R80R + ST100R)
Wheels Ø 80 mm

Double clothes stand, width cm 100. Tube Ø 30 mm. Central and upper adjustable rail. Clamping with system "A" or "B".

	ST013R50R	ST013R80R
mm	h = min 1300 max 2030	h = min 1350 max 2000
mm	a = min 1000 max 1700	a = min 1000 max 1700
Kg	8,60	9,30
Pcs	100/pallet	100/pallet
CR	CR	CR
€	68,00	71,00
€	76,00	80,00

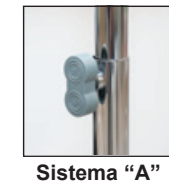
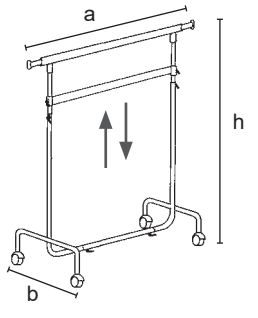

4.1 stender TT

4.1 stender TT



ST014R80F
Wheels Ø 80 mm

Fixed single clothes stand with upper bar for heavy loadings. Width 1500 mm, tube Ø 30 mm.

	ST014R80F
	h = 1580 a = min 1500 max 2200 b = 500
	7,60
	50/pallet
	CR
	71,00

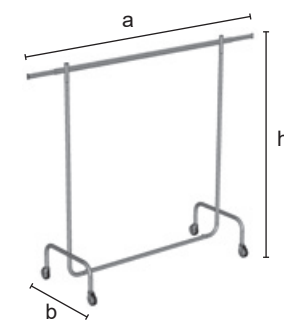

ST014R80R
Ruote Ø 80 mm / Wheels Ø 80 mm
Roues Ø 80 mm / Koneca Ø 80 mm

Height-adjustable clothes stand with upper bar for heavy loadings. Width 1500 mm, tube Ø 30 mm. Clamping with system "A" or "B".

	ST014R80R
	h = min 1250 max 2000 a = min 1500 max 2200 b = 500
	8,50
	50/pallet
	CR
	"A" € 76,00
	"B" € 81,00

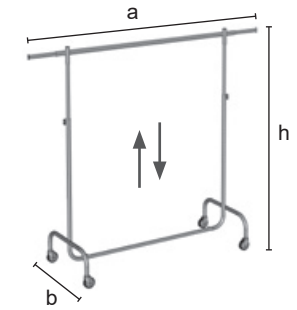

Sistema "A"

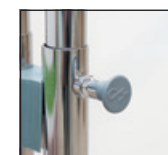

Sistema "B"

ST209R80B

Height-adjustable clothes-stand with double bar. Width 150cm, wheels Ø80, two of which with brake. Upper bar with extensions.



	ST209R80B
	h = min 1250 max 2000 a = min 1500 max 2000 b = 530
	13,00
	40/pallet
	CR
	99,00

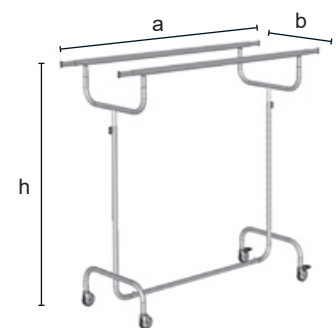



4.1 stender TT

4.1 stender TT



GIDKIT20

Height-adjustable garment rail realized with Idroshop tubes and joints Ø 28 mm. Supplied in KD form.

	GIDKIT20
	h = min 1200 max 2000 a = 1200 b = 450
	13,80
	50/pallet
	ZN
	85,00

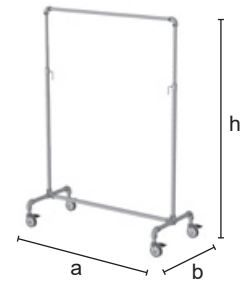

GIDKIT55

Garment rail realized with Idroshop tube and joints Ø 28 mm. Available in fixed height, 2 levels. Supplied in KD form.

	GIDKIT55
	h = min 1600 max 2000 a = 1200 b = 450
	11,00
	50/pallet
	ZN
	85,00

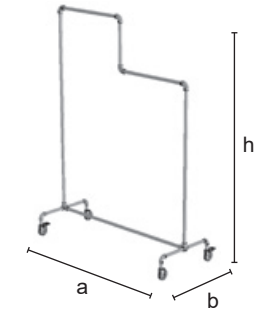

GIDKIT21

Garment rail realized with Idroshop tubes and joints Ø 28 mm. Fixed height, supplied in KD form.

	GIDKIT21
	h = 1600 a = 1200 b = 450
	10,00
	50/pallet
	ZN
	80,00

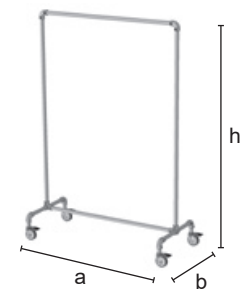





4.1 stender TT

4.1 stender TT



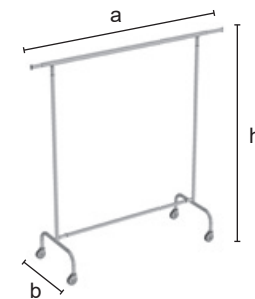

**ST008R80F**

Garment rail with fixed height, fully demountable. The special connecting lower base allows the rails to be easily stacked when not in use. The upper bar is always supplied in chrome finishing while the structure can be in chrome finishing or laquered in the colours of our range.

	ST008R80F	
	h = 1600 a = 1500 b = 540	
mm		
	Kg 7,70	
	Pcs 75/pallet	
	CR - VS	V
€	58,00	56,00

**ST008R80R**

Height-adjustable garment rail, fully demountable. The special connecting lower base allows the rails to be easily stacked when not in use. The upper bar is always supplied in chrome finishing while the structure can be in chrome finishing or laquered in the colours of our range.

	ST008R80R	
	h = min 1400 max 2000 a = 1500 b = 540	
mm		
	Kg 8,00	
	Pcs 75/pallet	
	CR - VS	V
€	63,00	61,00

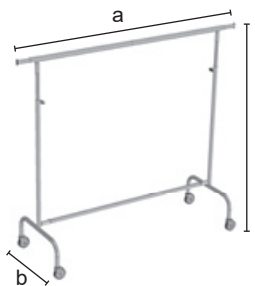

4.1 stender TT

4.1 stender TT



SST05EC
Wheels Ø 50 mm

Clothes-stand in tube Ø 25, width 1200 mm. Fixed height. Chromed or laquered finishing.

M	SST05EC	
	h = 1500	
	a = 1200	
	b = 570	
	6,50	
	50/pallet	
	CR - VS	V
€	49,00	40,00

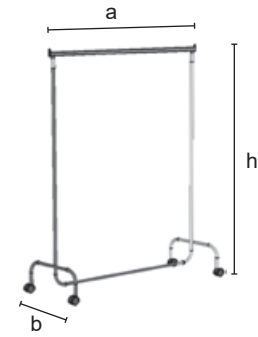

SST004
Wheels Ø 50 mm

Clothes-stand with adjustable width 700/1200 mm. Height-adjustable, chrome-plated finishing. Clamping with system "A" or "B".

M	SST004	
	h = min 1130 max 1900	
	a = min 850 max 1560	
	b = 600	
	c = 360	
	5,40	
	60/pallet	
	CR	
"A" €	52,00	
"B" €	56,00	

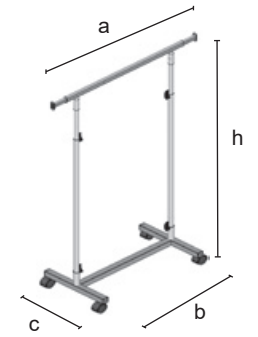

ST070PR / ST070R50
Adjustable double overhanging clothes-stand.

M	ST070PR	ST070R50
	h = min 1100 max 2000	h = min 1100 max 2000
	a = 1300	a = 1300
	b = 630	b = 630
	10,50	10,50
	40/pallet	40/pallet
	CR	CR
€	120,00	127,00

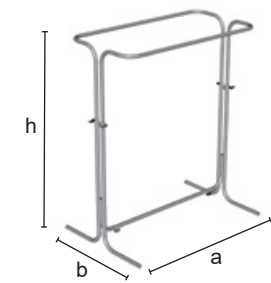

ST009R50R
Ruote Ø 50 mm / Wheels Ø 50 mm
Roues Ø 50 mm / Koneca Ø 50 mm

Adjustable clothes stand with whole base. Upper adjustable rail. Clamping with system "A" or "B".

M	ST009R50R	
	h = min 1120 max 1850	
	a = min 970 max 1700	
	b = 500	
	c = 830	
	5,90	
	50/pallet	
	CR	
"A" €	54,00	
"B" €	58,00	

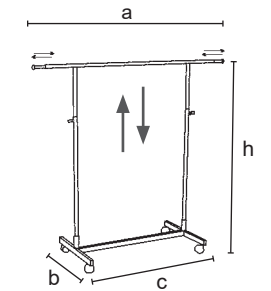
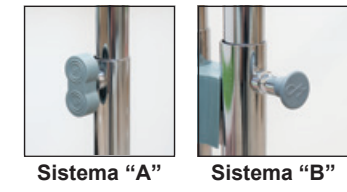



4.1 stender TT

4.1 stender TT



ST012VTMA

Stand with clothes-bar and height-adjustable basket. Chrome finishing. It is supplied unassembled.



M	ST012VTMA
	h = 1600 a = min 1000 max 1400 b = 500
	8,60
	1/pallet
	CR
€	80,00



ST012VTMB

Stand with height-adjustable baskets. Chrome finishing. It is supplied unassembled.



M	ST012VTMB
	h = 1600 a = 1000 b = 500
	11,00
	1/pallet
	CR
€	139,00



4.1 stender TT







4.1 stender TT



ST030PR
With feet

ST030R50R
Wheels Ø 50 mm

Column clothes stand with four adjustable independent overhanging arms inclined at 25°. Clamping adjustment by means of levers.



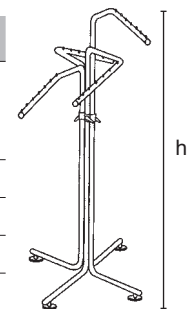



	ST030PR	ST030R50R
	h = min 1100 max 1800	h = min 1100 max 1800
	10,10	10,10
	50/pallet	50/pallet
	CR	CR
	114,00	116,00



ST032PR
With feet

ST032R50R
Wheels Ø 50 mm

Column clothes stand with four adjustable independent side overhanging arms inclined at 90°. Clamping adjustment by means of levers.



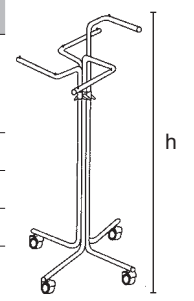



	ST032PR	ST032R50R
	h = min 1100 max 1800	h = min 1100 max 1800
	10,00	10,00
	50/pallet	50/pallet
	CR	CR
	110,00	112,00



ST031PR
With feet

ST031R50R
Wheels Ø 50 mm

Column clothes stand with three adjustable independent arms inclined at 25°. Clamping adjustment by means of levers.

	ST031PR	ST031R50R
	h = min 1100 max 1800	h = min 1100 max 1800
	7,00	7,00
	100/pallet	100/pallet
	CR	CR
	86,00	87,00

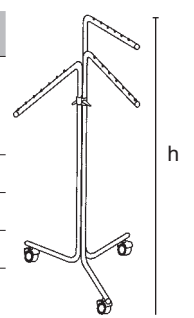



4.1 stender TT

4.1 stender TT



ST042R50F

Wheels Ø 50 mm

Adjustable double spiral clothes stand.

M	ST042R50F
	h = 1650 a = 680 b = 600
	8,20
	25/pallet
	CR
	135,00

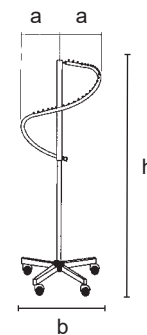

ST050R50A

Ring Ø 800

Circular clothes stand with a single circle Ø 800 rotating on a nylon ring. Clamping adjustment by clips.

M	ST050R50A
	h = min 1200 max 2000 a = 800 b = 800
	12,70
	20/pallet
	CR
	161,00

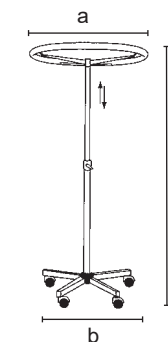

ST054R50R

Ring Ø 800

Circular clothes stand with a double circle Ø 800 rotating on a nylon ring. Clamping adjustment by means of levers.

M	ST054R50R
	h = min 1250 max 2000 a = 800 b = 800
	17,50
	15/pallet
	CR
	248,00

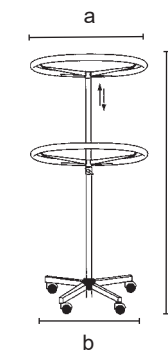



4.1 stender TT

4.1 stender TT



ST051R50R
Wheels Ø 50 mm

Circular clothes stand with a single circle Ø 600 mm rotating on a nylon ring. Clamping adjustment by means of levers.

	ST051R50R
	h = 1650 a = 600 b = 600
	7,30
	50/pallet
	CR
	140,00

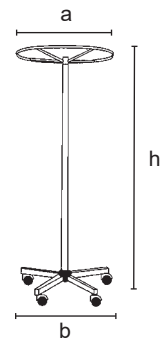

ST052R50R
Wheels Ø 50 mm

Adjustable circular belt-holder with 8 spokes.

	ST052R50R
	h = 1650 a = 600
	6,30
	20/pallet
	CR
	106,00

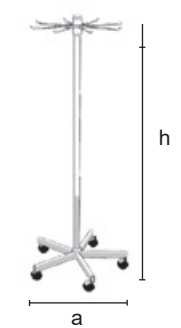

ST055

Hat-holder stand with three height-adjustable supports with 4 arms each. The twelve hat-supports are made by soft polyurethane, grey finishing. The stand has a 5-spoked base with wheels Ø50. Chrome finishing.

	ST055
	h = 1650 a = 600
	7,00
	15/pallet
	CR
	160,00

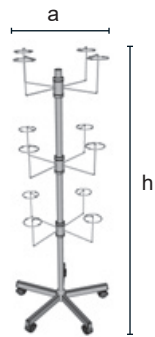

ST057

Belt-holder stand with two crowns at 8 spokes. The crowns are height-adjustable.

	ST057
	h = 1650 a = 600
	8,00
	15/pallet
	CR
	153,00

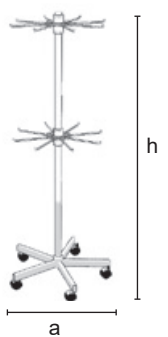
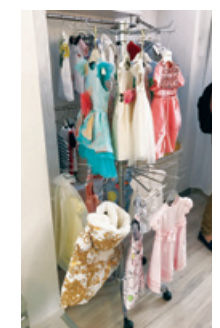



4.1 stender TT

4.1 stender TT



ST061R50F
Wheels Ø 50 mm

Shoes-holder with five levels.



M	ST061R50F
	h = 1400 a = 1000
mm	
	Kg 11,80
	Pcs 40/pallet
	CR
€	128,00



ST061D
Wheels Ø 80 mm

Double-sided Gondola system for shoes. The grid shelves are inclinable. Chrome finishing.

M	ST061D
	h = 1450 a = 1100 b = 500
mm	
	Kg 20,00
	Pcs 1/pallet
	CR
€	235,00





4.1 stender TT

4.1 stender TT



GIDKIT3

2-arms clothes-stand realized with tubes and joints of Idroshop collection. The structure is supplied as a kit, with cutted tubes and all the assembling tooling.



M	GIDKIT3
	h = 1300 a = 700 b = 450
	7,00
	50/pallet
	ZN
	65,00

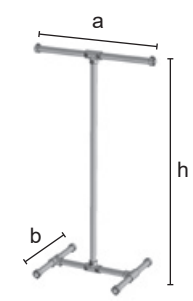

GIDKIT5

Clothes-stand realized with tubes and joints of Idroshop collection. The structure is supplied as a kit, with cutted tubes and all the assembling tooling.



M	GIDKIT5
	h = 1580 a = 1560 b = 570
	14,00
	50/pallet
	ZN
	102,00

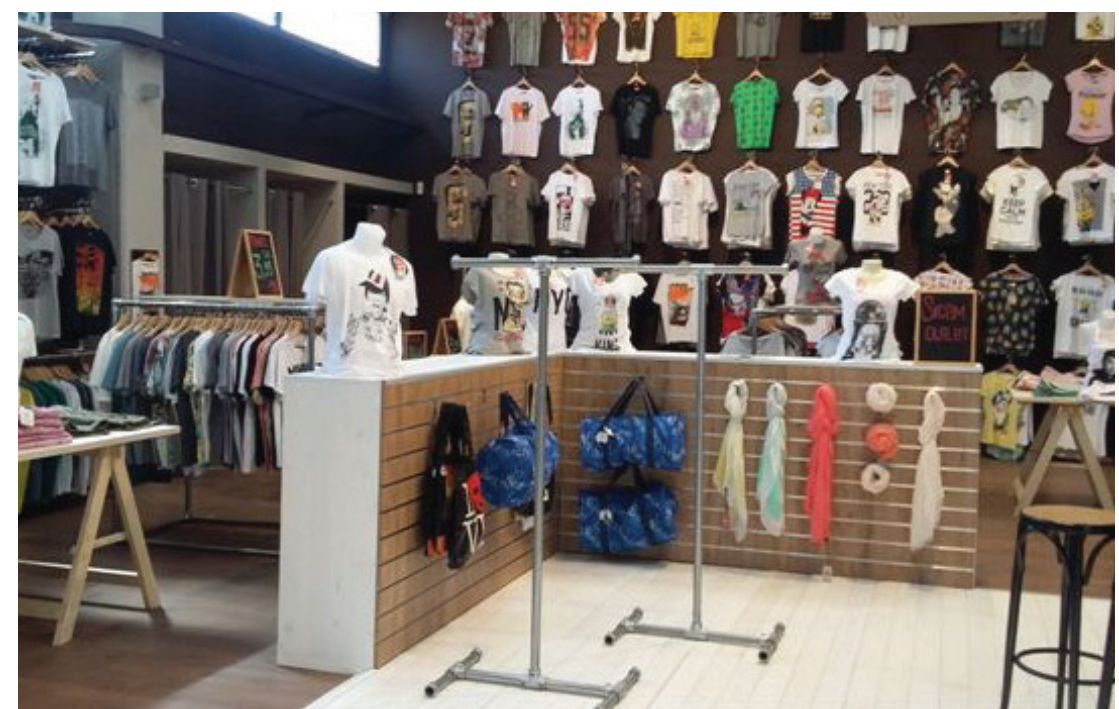

4.2 stender TQ











Stender in tubo quadro



ST018R80F

Heavy loading clothes stand. Width cm 200.

	ST018R80F
	h = 1800
	a = 2060
	b = 580
	Kg 13,50
	Pcs 30/pallet
	V
	€ 128,00

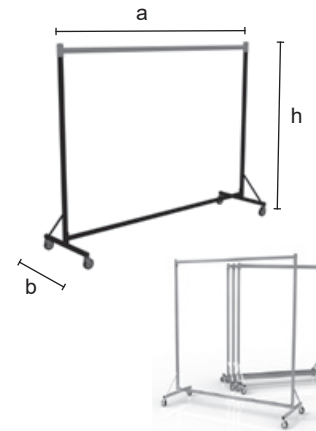







4.2 stender TQ

4.2 stender TQ

ST020R100R

Heavy duty rail, height-adjustable by clip system. The base and the side-legs are lacquered in the finishings of our range while the upper bar and the height extensions are always in chrome finishing. The Z-base allows the rails to be stacked when not in use.





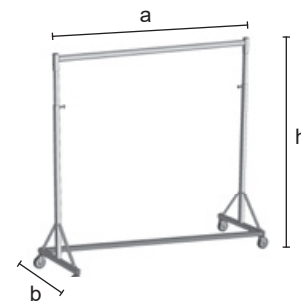



	ST020R100R
	h = min 1200 max 1950 a = 1500 b = 550
	12,50
	40/pallet
	V
	115,00

**ST020RBC**

Middle bar for rail ST020R100R. Height-adjustable by screw, chromed finishing.



	ST020RBC
	h = 35 a = 1500 b = 35
	2,50
	300/pallet
	V
	24,00

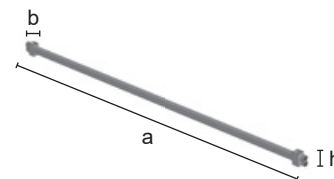

4.2 stender TQ

4.2 stender TQ



TRP008
Wheels Ø 80 mm

Fixed stand on wheels in square tube 30x30 mm.

	TRP008	
	h = 1650	
mm	a = 1560	
	b = 500	
	13,50	
	50/pallet	
	CR - VS	V
€	129,00	99,00

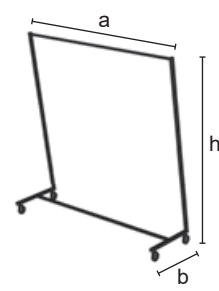

NVR004
Wheels Ø 80 mm

Fixed stand of Inverso collection, realized in tube 30x30 with upper bar in round tube d.25mm. The stand is supplied unassembled.

	NVR004	
	h = 1640	
mm	a = 1340	
	b = 520	
	13,50	
	60/pallet	
	CR - VS	V
€	105,00	80,00

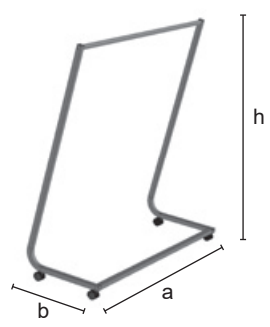

4.2 stender TQ

4.2 stender TQ



ST048F
Straight clothes-stand.

M	ST048F
	h = 1350 a = 500 b = 250
mm	
	7,00
	50/pallet
	CR
€	81,00

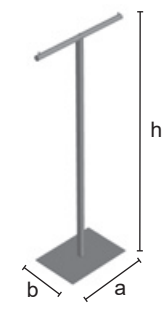

ST049F
Double belt-stand.

M	ST049F
	h = 1350 a = 500 b = 300
mm	
	9,00
	25/pallet
	CR
€	94,00

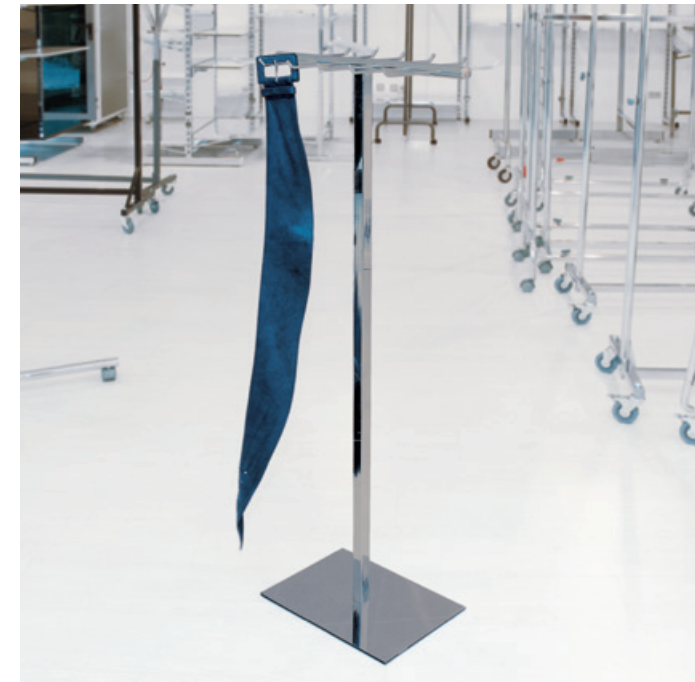

4.2 stender TQ

4.2 stender TQ



ST127

Stand with 2 height-adjustable arms, chrome finishing. It is supplied unassembled.

	ST127
	h = min 1100 max 1800 a = 710 b = 500 c = 350
	7,00
	50/pallet
	CR
€	95,00

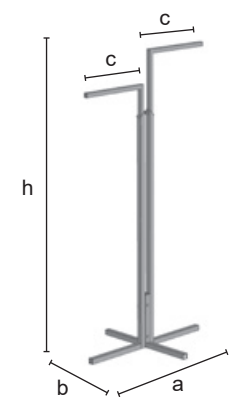

ST128

Stand with 3 height-adjustable arms, chrome finishing. It is supplied unassembled.

	ST128
	h = min 1100 max 1800 a = 600 b = 600 c = 350
	9,20
	50/pallet
	CR
€	118,00

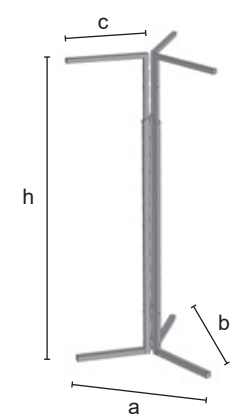

ST129

Stand with 4 height-adjustable arms, chrome finishing. It is supplied unassembled.

	ST129
	h = min 1220 max 1720 a = 760 b = 760 c = 350
	12,80
	40/pallet
	CR
€	161,00

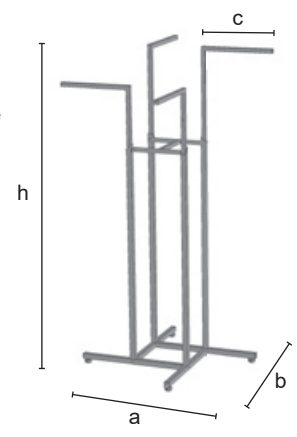

ST117 / ST118 / ST119

Stand in square tube 25x25 available in 3 widths. The stand is delivered with unassembled base

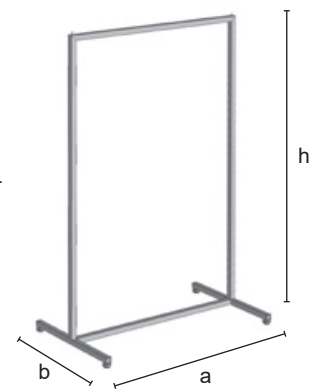

	ST117	ST118	ST119
	h = 1520 a = 600 b = 500	h = 1520 a = 900 b = 500	h = 1520 a = 1200 b = 500
	5,00	5,60	5,90
	100/pallet	50/pallet	50/pallet
	CR - VS V	CR - VS V	CR - VS V
€	80,00	56,00	88,00
		65,00	96,00
			86,00

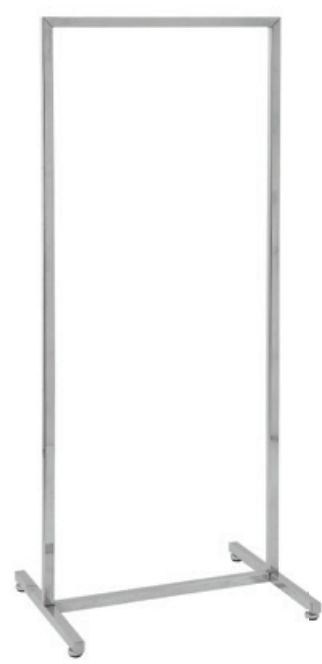

Stender pieghevoli







ST063R80F

Wheels Ø 80 mm

Folding clothes stand with drop-leaf base, width cm 150.



ST063R80F

 mm	h = 1460 a = min 1500 max 2200 b = 490
 Kg	8,20
 Pcs	50/pallet
 CR	CR
€	74,00

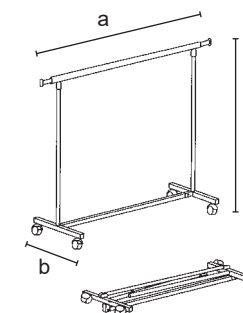





ST063R80R

Wheels Ø 80 mm

Folding and height adjustable clothes stand with drop-leaf base, width cm 150. Clamping with system "A" or "B".

ST063R80R

 mm	h = min 1180 max 1900 a = min 1500 max 2200 b = 490
 Kg	9,20
 Pcs	50/pallet
 CR	CR
"A" €	82,00
"B" €	86,00

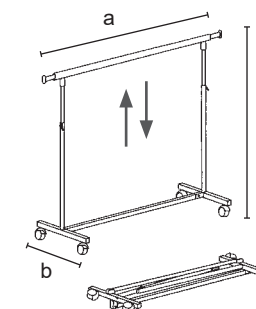

Sistema "A"

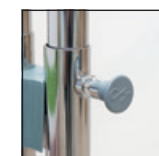

Sistema "B"

4.3 stender P

4.3 stender P



SST63BF
Wheels Ø 80 mm

Folding clothes stand with drop-leaf base, width cm 150, upper bar for heavy loadings.



	SST63BF
	h = 1460 a = min 1500 max 2200 b = 490
	8,40
	50/pallet
	CR
	€ 88,00

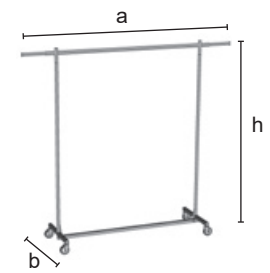

SST63BR
Wheels Ø 80 mm

Folding and height adjustable clothes stand with drop-leaf base, width cm 150. Clamping with system "A" or "B".

	SST63BR
	h = min 1170 max 1890 a = min 1500 max 2200 b = 490
	9,20
	50/pallet
	CR
	"A" € 94,00
	"B" € 98,00

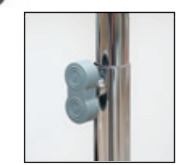
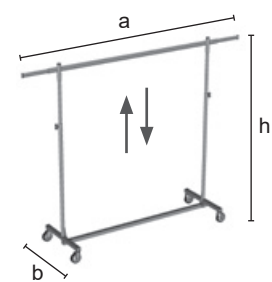

Sistema "A"



Sistema "B"



ST065R80R
Wheels Ø 80 mm

Folding and height adjustable clothes stand with drop-leaf base, width cm 100. Clamping with system "A" or "B".

	ST065R80R
	h = min 1170 max 1890 a = min 1000 max 1700 b = 490
	8,20
	50/pallet
	CR
	"A" € 75,00
	"B" € 80,00

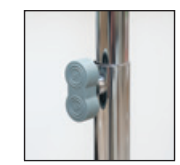
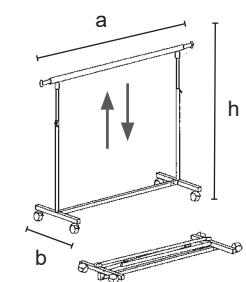

Sistema "A"



Sistema "B"



4.3 stender P

ST026R50R

Folding stand with adjustable height and width. It takes little space when folded.



M	ST026R50R
	h = min 1100 max 1800 a = min 800 max 1500 b = 450
	6,00
	1/pack
	CR - VS
	V
€	44,00 41,00

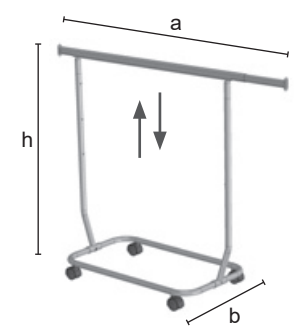

4.3 stender P

ST028R80R

Folding stand adjustable in height and width. The strong structure allows to support loads up to 80kg. (static load well distributed). It takes little space when folded.



M	ST028R80R
	h = min 1200 max 2000 a = min 1300 max 1900 b = 540
	10,50
	1/pack
	CR - VS
	V
€	75,00 67,00

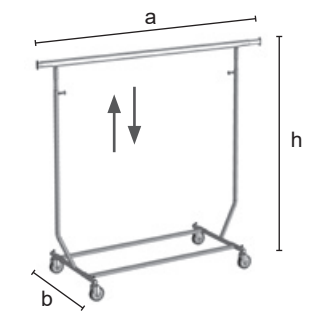



4.3 stender P

4.3 stender P



ST021R80R

Wheels Ø 80 mm (2 braking wheels)

Adjustable clothes stand for agents. Clamping adjustment by means of levers.

	ST021R80R
	h = min 950 max 1670 a = min 850 max 1570 b = 750
	6,50
	20/pallet
	CR
	85,00

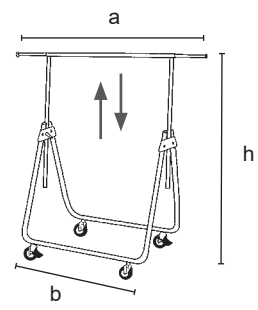

ST022R80R

Completely folding stand for agents.

	ST022R80R
	h = min 1600 max 2000 a = min 980 max 1700 b = 600
	8,00
	40/pallet
	CR
	117,00

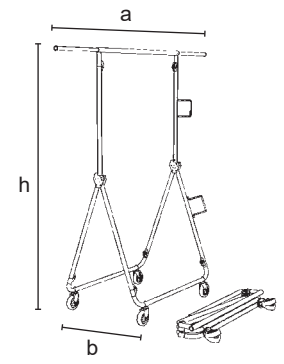

ST022R80F

Completely folding stand for agents.

	ST022R80F
	h = 1600 a = min 980 max 1700 b = 560
	8,00
	40/pallet
	CR
	106,00

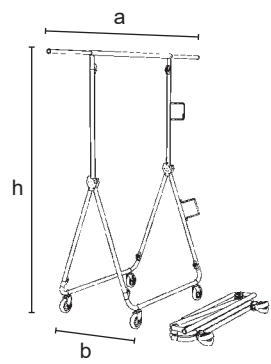





Gondole

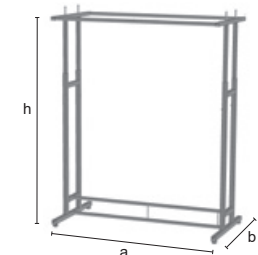

ST101PR / ST101R80R

Height-adjustable gondola system with or without glass top (ST101CR). Chrome finishing.







	ST101PR	ST101R80R
 mm	h = min 1100 max 1500 a = 1160 b = 600	h = min 1100 max 1500 a = 1160 b = 600
 Kg	16,00	16,00
 Pcs	40/pallet	40/pallet
 CR	CR	CR
€	193,00	209,00



ST101CR

Acid-etched glass.

	ST101CR
 mm	a = 1200 b = 350
 Kg	7,60
 Pcs	40/pallet
 CR	--
€	54,00

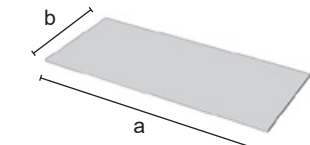

4.4 gondole

4.4 gondole

ST105PR

Gondola for panels. For use with panels of 1200x1200 mm size and thickness 18/20 mm. The metal structure is fully demountable and available in laquered finishing in the colours of our range. Panels not included.

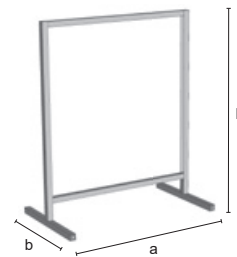

ST105PR	
mm	h = 1450 a = 1205 b = 700
Kg	18,00
Pcs	50/pallet
	V VS
€	106,00 124,00

**ST106PR**

Gondola for panels. For use with panels of 1200x2000 mm size and thickness 18/20 mm. The metal structure is fully demountable and available in laquered finishing in the colours of our range. Panels not included.



ST106PR	
mm	h = 2250 a = 1205 b = 700
Kg	19,50
Pcs	30/pallet
	V VS
€	123,00 143,00

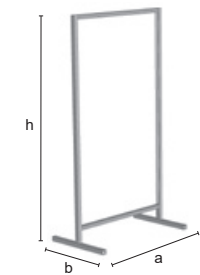





4.4 gondole

4.4 gondole

GIDKIT61A

Gondola at two heights realized with Idroshop tubes and joints Ø 28 mm. Each side can be equipped with shelves. Supplied in KD form, wooden shelves not included.





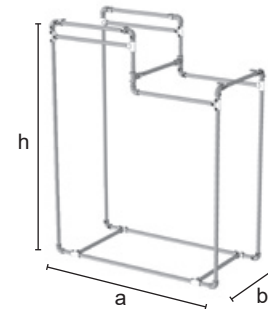

M	GIDKIT61A
	h = 1500 a = 1200 b = 600
	47,00
	15/pallet
	ZN
€	162,00

**GIDKIT61B**

Gondola at two heights realized with Idroshop tubes and joints Ø 28 mm. Each side can be equipped with shelves. Supplied in KD form, wooden shelves not included.





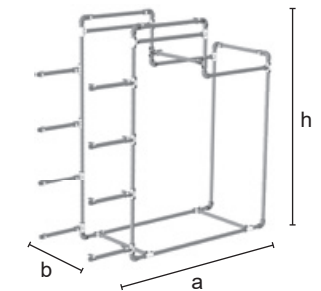

M	GIDKIT61B
	h = 1500 a = 1600 b = 600
	59,00
	15/pallet
	ZN
€	255,00

**GIDKIT61C**

Gondola at two heights realized with Idroshop tubes and joints Ø 28 mm. Each side can be equipped with shelves. Supplied in KD form, wooden shelves not included.



M	GIDKIT61C
	h = 1500 a = 2000 b = 600
	68,00
	10/pallet
	ZN
€	348,00

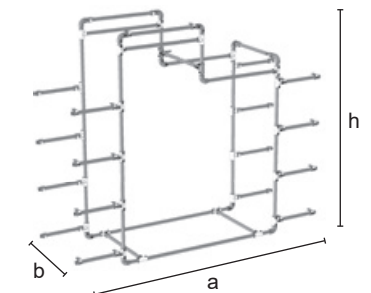

Articoli per rappresentanti



ST880

Telescopic vehicle rail. Studied for the vans transporting garments.



M	ST880
	a = min 1200 max 1550
	b = 32
	c = 40
mm	
	1,70
	1/pack
	CR
€	28,00

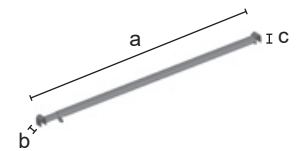

ST881

Telescopic vehicles rail. Studied for the cars, clips onto the grab handles in the rear of the car. Useful accessory for representatives of garments.



M	ST881
	a = min 800 max 1050
	b = 32
	c = 40
mm	
	1,50
	1/pack
	CR
€	26,00

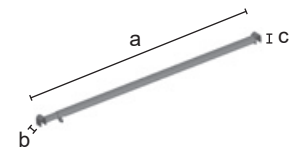

Accessori

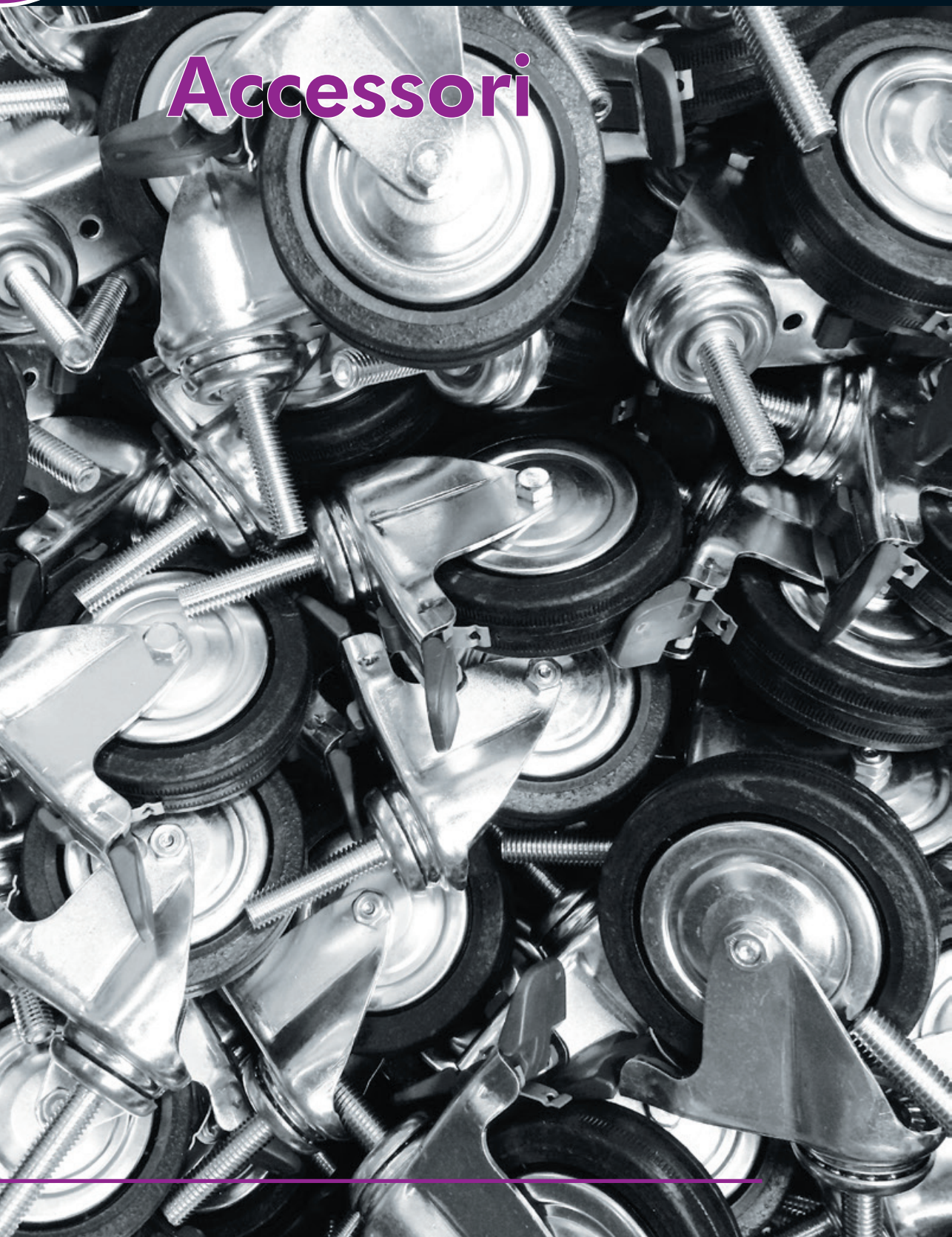

ST080R80

With rapid clutch, without brake

ST081R80



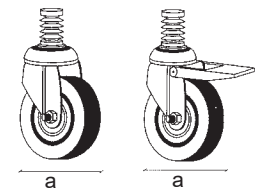



With rapid clutch, with brake



a
ST080 R 80

a
ST081 R 80

Wheels Ø 80 mm.

	ST080R80	ST081R80
	a = 80	a = 80
	24,00 (box)	24,00 (box)
	60/box	60/box
	ZN 020	ZN 020
	2,70	3,50



ST078R80

With brake

ST079R80



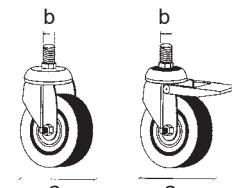



Without brake



a
ST079 R 80

a
ST078 R 80

Wheels Ø 80 mm M10 threaded fixing.

	ST078R80	ST079R80
	a = 80 b = 10 MA	a = 80 b = 10 MA
	24,00 (box)	24,00 (box)
	60/box	60/box
	ZN 020	ZN 020
	3,55	3,11

4.6 accessori

4.6 accessori



ST082R50

With M10 threaded connection

ST083R50

With rapid clutch

Wheels Ø 50 mm.

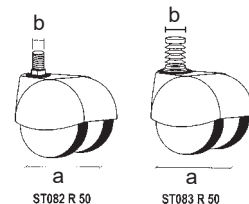

	ST082R50	ST083R50
	a = 50 b = 10 MA	a = 50 b = 10 MA
mm		
	8,80 (box)	8,80 (box)
	100/box	100/box
	020	020
€	1,40	1,70



ST077PR

Adjustable 10 MA foot.



	ST077PR
	a = 35 b = 14 c = 17 d = 10 MA
mm	
	11,80 (box)
	300/box
	CR
€	0,70

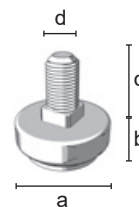

ST101

Fixed bar for hooks.



	ST101
	a = 1100
mm	
	11,00 (box)
	50/box
	CR
€	3,90

